

ISO VIEW
SCALE 1 / 12

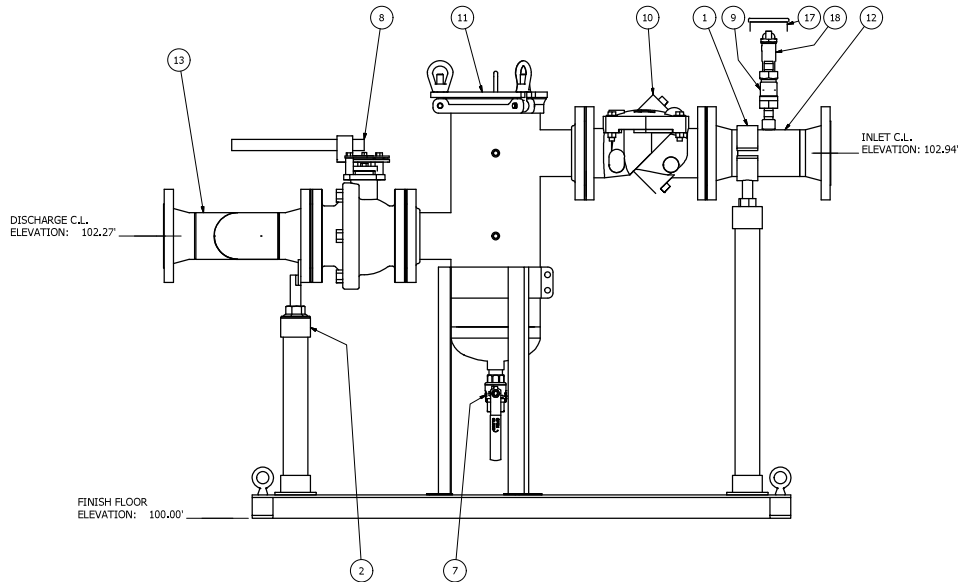

PARTS LIST			
ITEM	QTY	STOCK NUMBER	DESCRIPTION
1	2	25-PS04C00S	PIPE STAND - CLAMP - 4in
2	2	25-PS04RUFL	PIPE STAND - 304SS - 4in FLANGE
3	4	25-PS08BASE	PIPE STAND BASE - 304SS - 2in - 2 BOLT
4	7.3 ft	48-PP020054	PIPE - 304SS SCH40 - 2in DIA
5	2	48-TT010256	NIPPLE - 316SS - 1in DIA x 2in
6	4	48-TT010256	NIPPLE - 316SS - 0.5in DIA x 2in
7	2	41-BV010056	BALL VALVE - 316SS - 4in
8	2	41-BV040056	BALL VALVE - 316SS - 4in - FLGXFLG
9	2	41-BV080056	BALL VALVE - 316SS - 0.5in
10	2	42-SF0400D0	CHECK VALVE - SWING FLEX - 4in
11	2	43-99999999	BASKET STRAINER - 4in FLGXFLG - 15in BASKET
12	2	45-FF999999	CUSTOM SPOOL - 316SS SCH40 - 4in
13	1	45-TE999999	CUSTOM MANIFOLD - 316SS SCH40 - 4in
14	2	48-PL0000HX	PLUG - 304SS - .25in NPT - HEX SOCKET
15	8	49-GS040000	GASKET - FLANGE - 4in
16	1	50-SK999999	SKID ASSEMBLY - STEEL
17	2	81-PG300000	PRESSURE GAUGE - 3.5in DIA x 30#
18	2	83-GI00FF00	DIAPHRAGM SEAL - 0.5in FNPT x 0.25in FNPT

FOR PRODUCTION

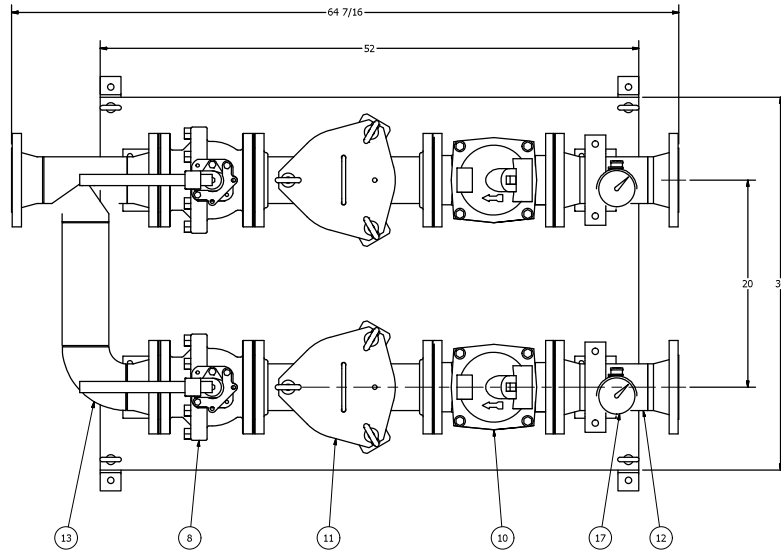
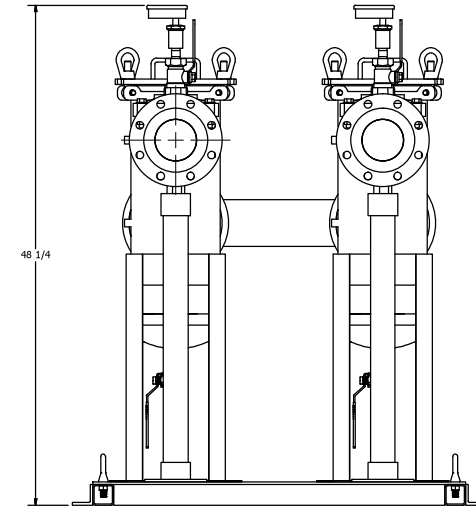

© 2019 ROMTEC INC. ALL RIGHTS RESERVED. THESE PLANS AND DRAWINGS MAY NOT BE REPRODUCED, ADAPTED, OR FURTHER DISTRIBUTED, AND NO COMPONENTS MAY BE CONSTRUCTED FROM THESE PLANS, WITHOUT WRITTEN PERMISSION OF ROMTEC, INC.

NOTE: ALL DIMENSIONS AND ELEVATIONS SHOWN ARE NOMINAL DIMENSIONS. IT IS THE RESPONSIBILITY OF THE ON-SITE CONTRACTOR OR ROMTEC UTILITIES CUSTOMER (NOT ROMTEC UTILITIES) TO VERIFY THE ACCURACY OF ANY CRITICAL DIMENSIONS OR ELEVATIONS PRIOR TO SETTING OR INSTALLING ANY EQUIPMENT.

REV	DATE	DESCRIPTION
1	12-31-19	DESIGN STRAINERS, ADDED STRAINERS
2	4/2/2019	PRODUCTION LAUNCH

DATE: 10-23-18

WEB SCALE
1" = 1'-0"

DKR: KEVIN BOGAN
DRN: KEVIN BOGAN
COD: P-31-19

WWW.ROMTECUTILITIES.COM

ROMTEC UTILITIES
18240 NORTH BANK ROAD
ROSEBURG, OREGON 97470
PHONE: (541) 896-6678
WWW.ROMTECUTILITIES.COM

TAKARA SAKE
BERKELEY, CA
VALVE ASSEMBLY
COMPONENT DRAWING