

WEIGHTS	
PARTS	WEIGHT
SKID ASSEMBLY PLATFORM	2270lbs
PIPING, PIPE SUPPORTS AND VALVES	1475lbs
SELF PRIMER PUMP ASSEMBLIES	3075lbs
OIL SKIMMER PUMP ASSEMBLY	260lbs
CONTROL PANEL	950lbs
TOTAL WEIGHT	8030lbs

DRAWING GEOMETRY IS ACCURATE AND CREATED AT 1:1 AND FIT TO THE SHEET. DO NOT SCALE THIS DRAWING.

REV	DESCRIPTION	DATE	APPROV
3	REVISION PER 5/16/13 COMMENTS	5-17-13	AD
2	REVISION PER 3/27/13 COMMENTS	4-9-13	AD
1	COMPONENT DRAWING	5-18-12	AD
REV		DATE	APPROV
CKD		11/28/11	

COMPONENT DRAWING

ROMTEC UTILITIES
 18240 NORTH BANK ROAD
 ROSEBURG, OREGON 97470
 (541) 496-9678
 FAX (541) 496-0804

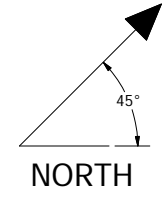
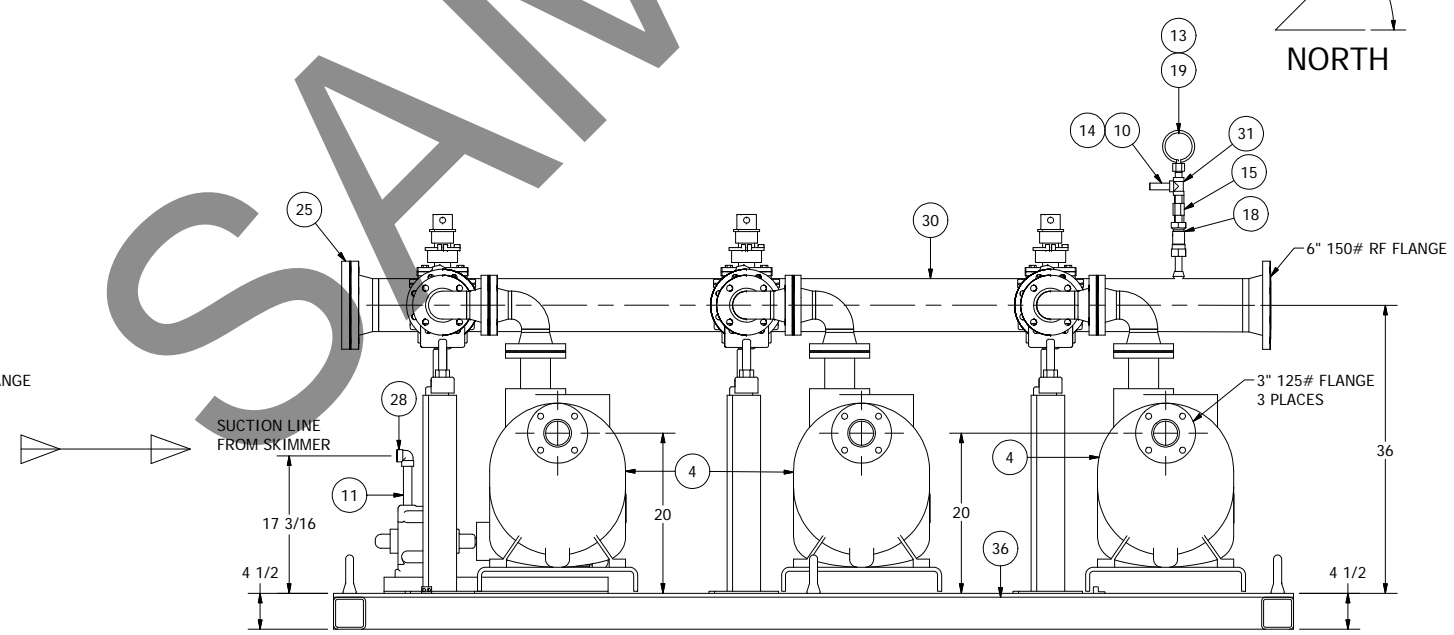
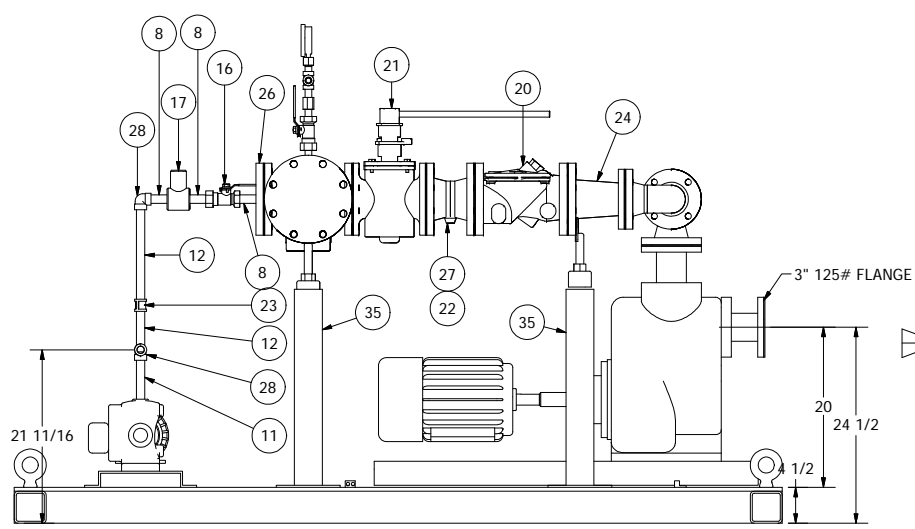

- COATING NOTES:**
- ALL STAINLESS STEEL OR ALUMINUM PARTS DO NOT NEED ADDITIONAL COATING.
 - ALL PLAIN STEEL PARTS, SKID PLATFORM, AND PIPING STANDS IF NOT STAINLESS STEEL SHALL BE COATED (SHOP APPLIED) WITH:
 - PRIME COAT - AMERCOAT 240
 - FINISH COAT - AMERSHIELD (BLACK)
- NOTES:**
- CONTROL PANEL TO BE LOCATED OFF OF SKID. SHIP FOR FIELD MOUNTING PER DRAWING 7651-1360.2005.
 - PIPE AND FITTINGS WILL HAVE HEAT TRACE AND INSULATION AS PER SPECIFICATIONS

© 2013 ROMTEC INC. ALL RIGHTS RESERVED. THESE PLANS AND DRAWINGS MAY NOT BE REPRODUCED, ADAPTED, OR FURTHER DISTRIBUTED, AND NO COMPONENTS MAY BE CONSTRUCTED FROM THESE PLANS, WITHOUT WRITTEN PERMISSION OF ROMTEC, INC.

NOTE: ALL DIMENSIONS AND ELEVATIONS SHOWN ARE NOMINAL DIMENSIONS. IT IS THE RESPONSIBILITY OF THE ON-SITE CONTRACTOR OR ROMTEC UTILITIES CUSTOMER (NOT ROMTEC UTILITIES) TO VERIFY THE ACCURACY OF ANY CRITICAL DIMENSIONS OR ELEVATIONS PRIOR TO SETTING OR INSTALLING ANY EQUIPMENT.