

TOP VIEW
SECTION B-B
SCALE 1 / 20

SENSOR AND ELEVATION TABLE		
LEVEL ELEVATION	DISTANCE BETWEEN POINTS	SET POINT DESCRIPTION
526.00'		INVERT IN
---		BACK UP PUMPS START
---		SENSOR SPACING
---		BACK UP PUMPS STOP
---		SENSOR SPACING
---		BACK UP HL ALARM
525.75'	0.50'	SENSOR SPACING
525.25'	0.50'	LAG PUMP START
524.75'	0.50'	SENSOR SPACING
524.75'	0.75'	LEAD PUMP START
524.00'	0.75'	SENSOR SPACING
524.00'		PUMP STOP
522.00'	2.00'	DISTANCE TO FLOOR
522.00'		FLOOR ELEVATION

NOTE: WET WELL TOP SLAB IS PEDESTRIAN RATED

5' DIAMETER WET WELL
3" DISCHARGE PIPING
EBARA 80DLMF PUMPS
3" CUSTOM VALVE VAULT

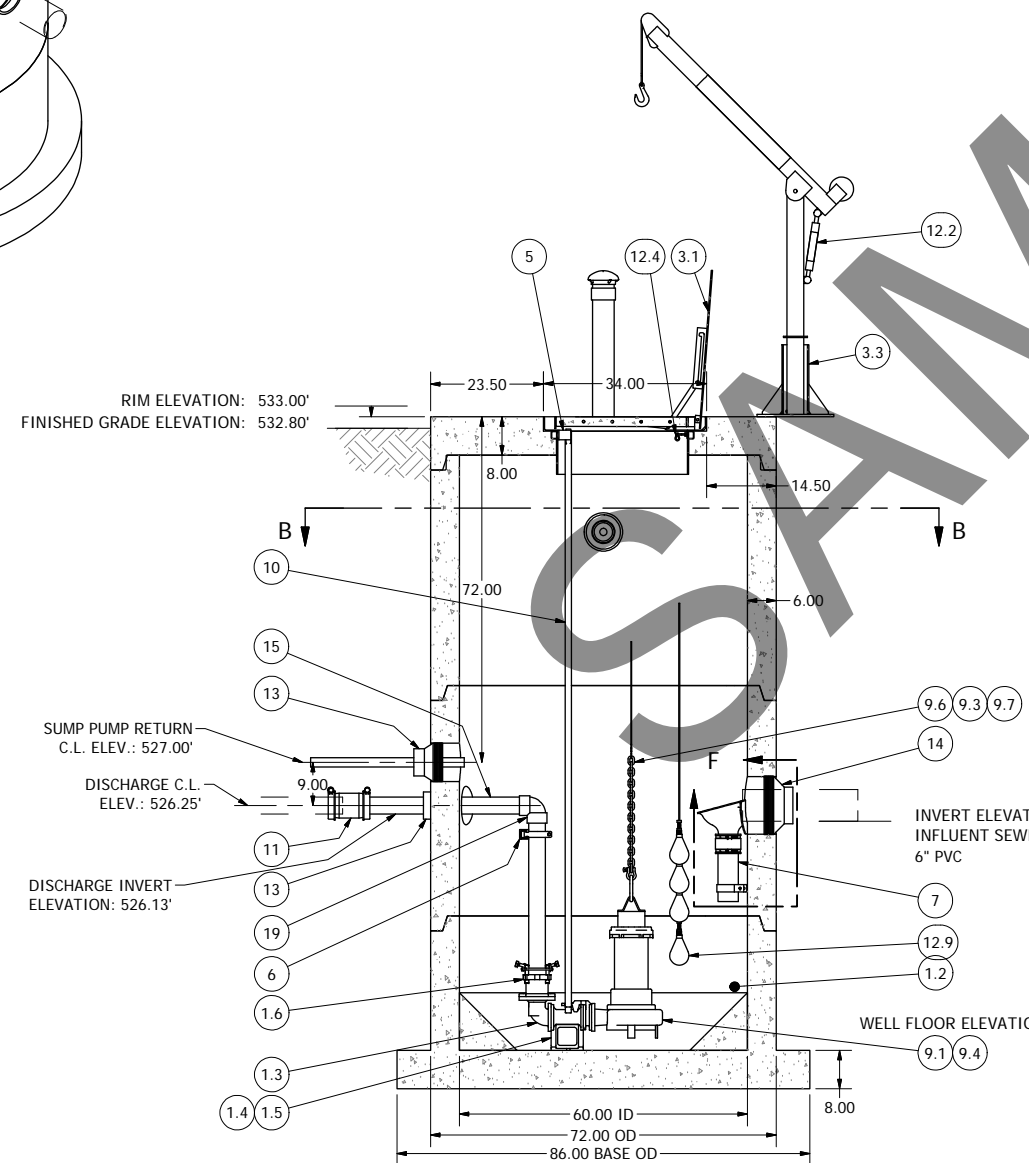

PROFILE VIEW SECTION - A-A
SCALE 1 / 20

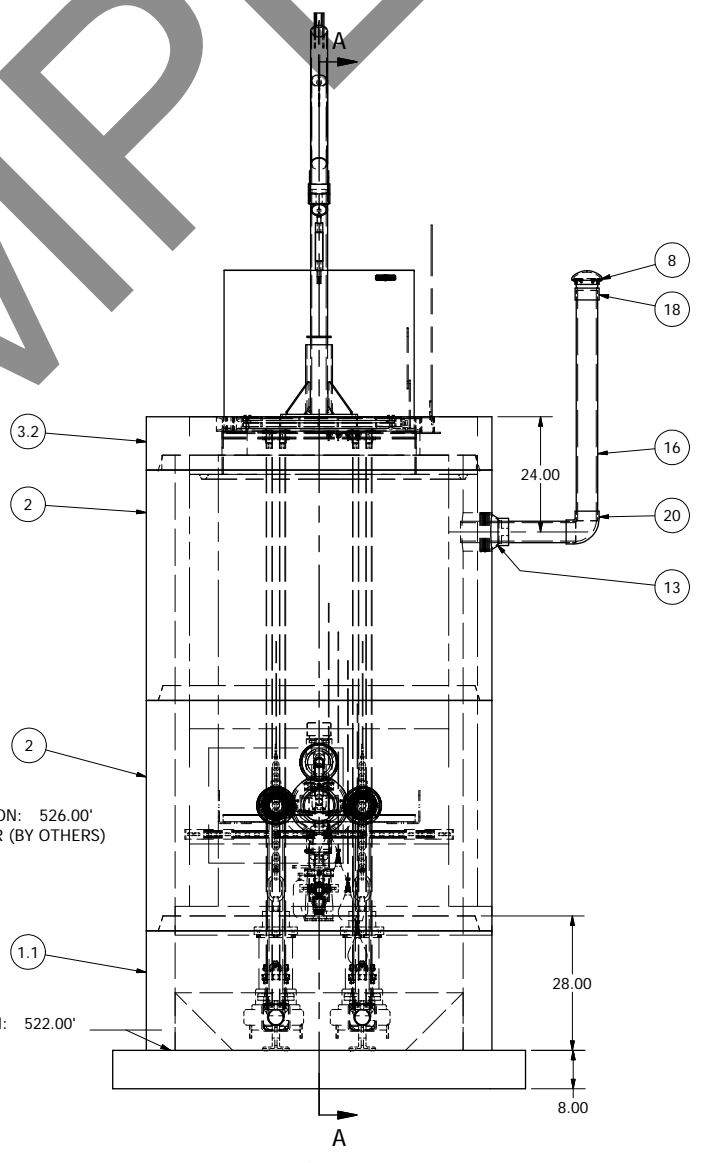

INLET SIDE VIEW
SCALE 1 / 20

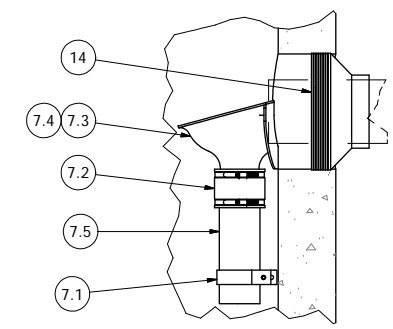

DETAIL F
SCALE 1 / 10

NOTE:
CONDUIT TO CONTROL PANEL (BY OTHERS)
MINIMUM:
(2) FOR POWER
(1) FOR LEVEL SENSING

ALL MATERIALS SHOWN ON THIS SHEET WILL BE SUPPLIED BY ROMTEC UTILITIES AND DELIVERED TO THE SITE AFTER THE HOLE HAS BEEN EXCAVATED AND SHORED. THE CONTRACTOR SHALL SUPPLY A CRANE OF SUFFICIENT SIZE TO LOWER ALL THE CONCRETE PIECES INTO THE HOLE SAFELY. THE CONTRACTOR SHALL INSTALL THE WET WELL (AND VALVE VAULT AND METERING VAULT IF APPLICABLE). ROMTEC UTILITIES WILL PROVIDE A REPRESENTATIVE FOR TECHNICAL ASSISTANCE ON THE DAY OF INSTALLATION TO ANSWER ANY QUESTIONS THAT MAY ARISE. THE CONTRACTOR IS RESPONSIBLE FOR ALL PLUMBING AND ELECTRICAL CONNECTIONS AND INSTALLATION. ITEMS NOTED AS "BY OTHERS" WILL BE PROVIDED AND INSTALLED BY THE CONTRACTOR. ROMTEC UTILITIES WILL NOT INSTALL ANY OF THE COMPONENTS SHOWN ON THIS PAGE.

© 2016 ROMTEC INC. ALL RIGHTS RESERVED. THESE PLANS AND DRAWINGS MAY NOT BE REPRODUCED, ADAPTED, OR FURTHER DISTRIBUTED, AND NO COMPONENTS MAY BE CONSTRUCTED FROM THESE PLANS, WITHOUT WRITTEN PERMISSION OF ROMTEC, INC.

VERIFY SCALE
BAR IS ONE INCH ON
ORIGINAL DRAWING
0 IF NOT ONE INCH ON
THIS SHEET, ADJUST
SCALE APPROPRIATELY

1"
DSN - KEVIN BOGAN
DRN - KEVIN BOGAN
CKD -
DATE - 5-12-16

2 REVISED ELEVATIONS AND ADDED DIMENSIONS 4-5-17 AD
1 ADD CRANE, PART NUMBER UPDATE 3-30-17 KB
0 INITIAL DESIGN 5-12-16 KB
REVI DESCRIPTION DATE APPROV

COMPONENT
DRAWING

ROMTEC UTILITIES
18240 NORTH BANK ROAD
ROSEBURG, OREGON 97470
(541) 496-9678
FAX (541) 496-0804

GCT ECTC
WET WELL ASSEMBLY

SHEET
1 OF 2

JOB NUMBER
RMTC
0000

NOTE: ALL DIMENSIONS AND ELEVATIONS SHOWN ARE NOMINAL DIMENSIONS. IT IS THE RESPONSIBILITY OF THE ON-SITE CONTRACTOR OR ROMTEC UTILITIES CUSTOMER (NOT ROMTEC UTILITIES) TO VERIFY THE ACCURACY OF ANY CRITICAL DIMENSIONS OR ELEVATIONS PRIOR TO SETTING OR INSTALLING ANY EQUIPMENT.

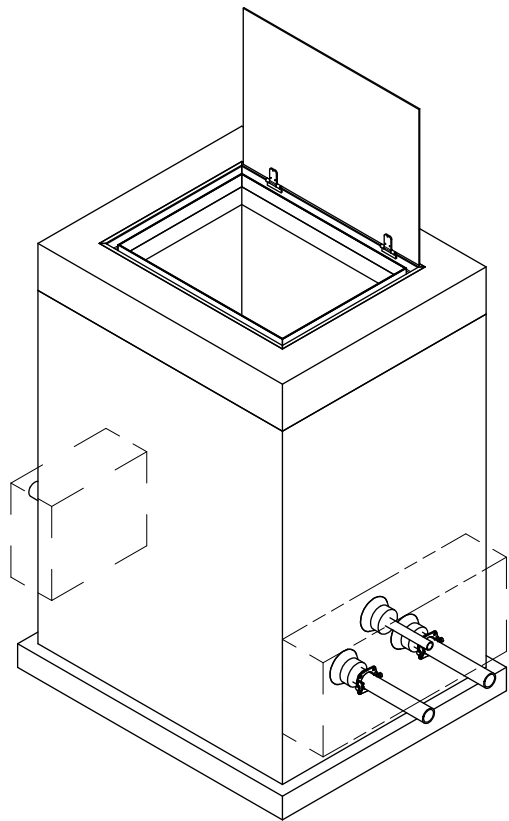

ISO VIEW
SCALE 1 / 20

660 VALVE VAULT
3" PIPING AND VALVES
W/ PUMPING PORT

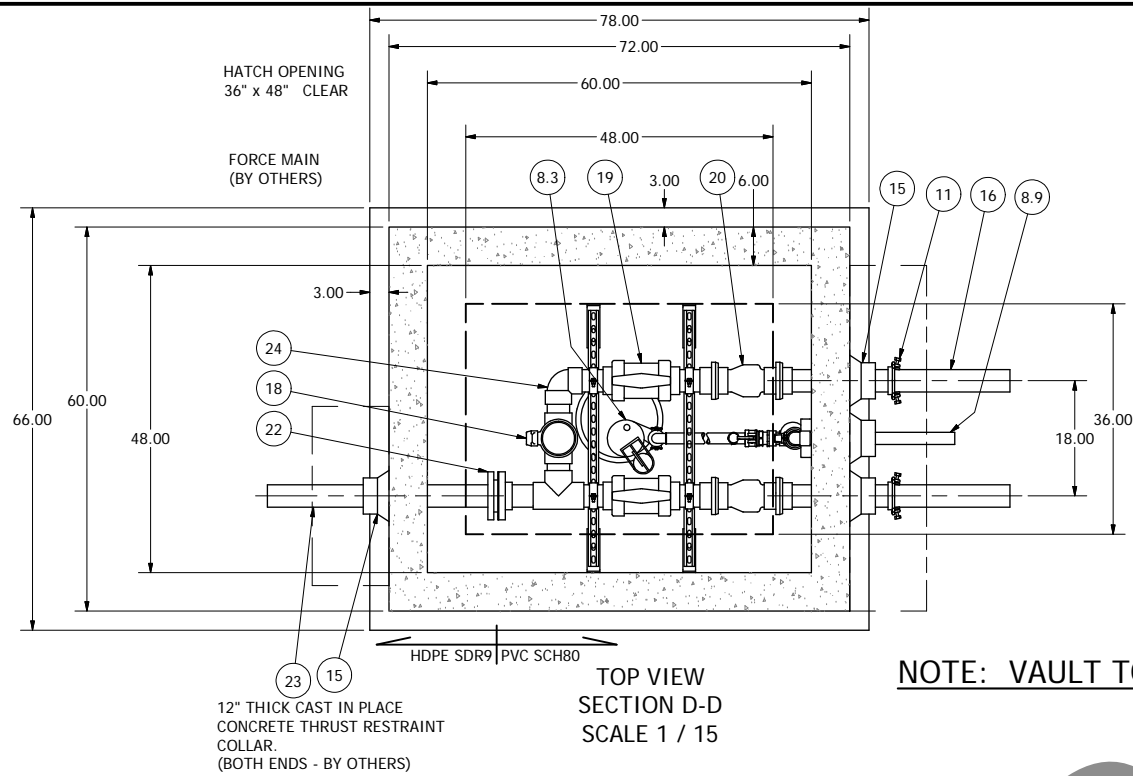

NOTE: VAULT TOP SLAB IS PEDESTRIAN RATED

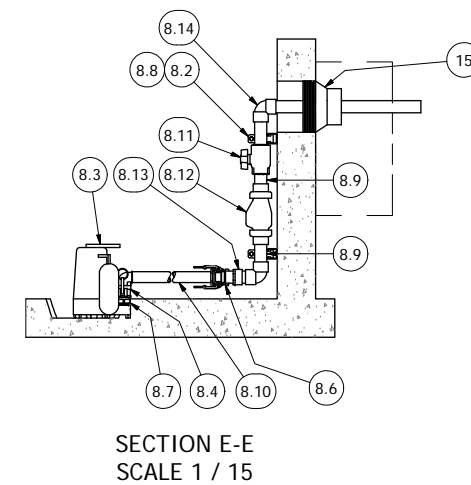
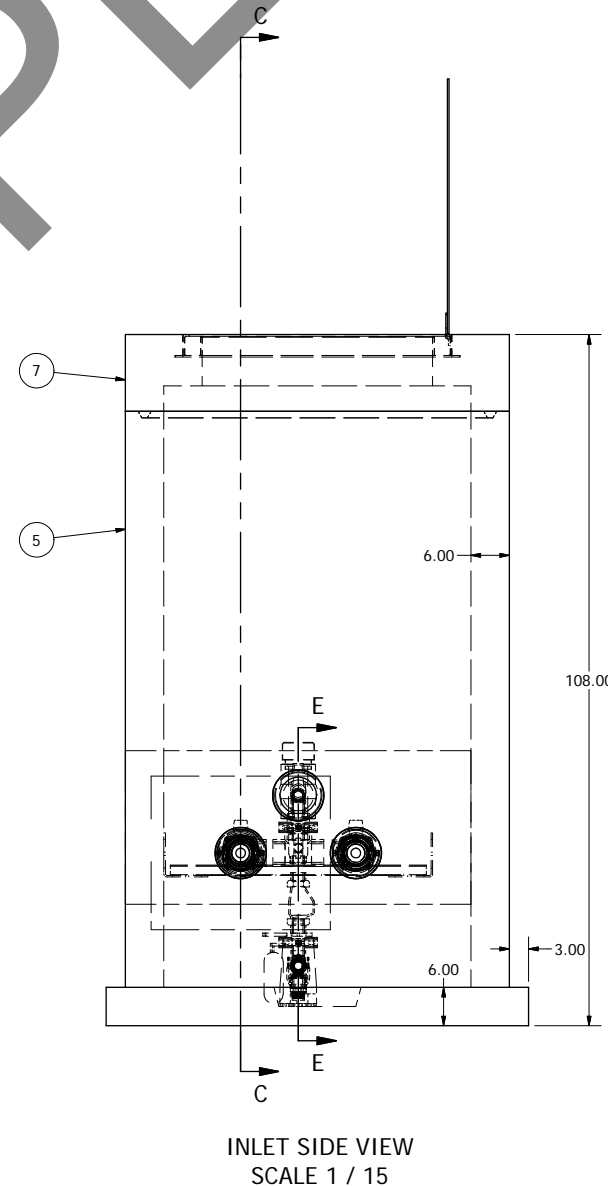
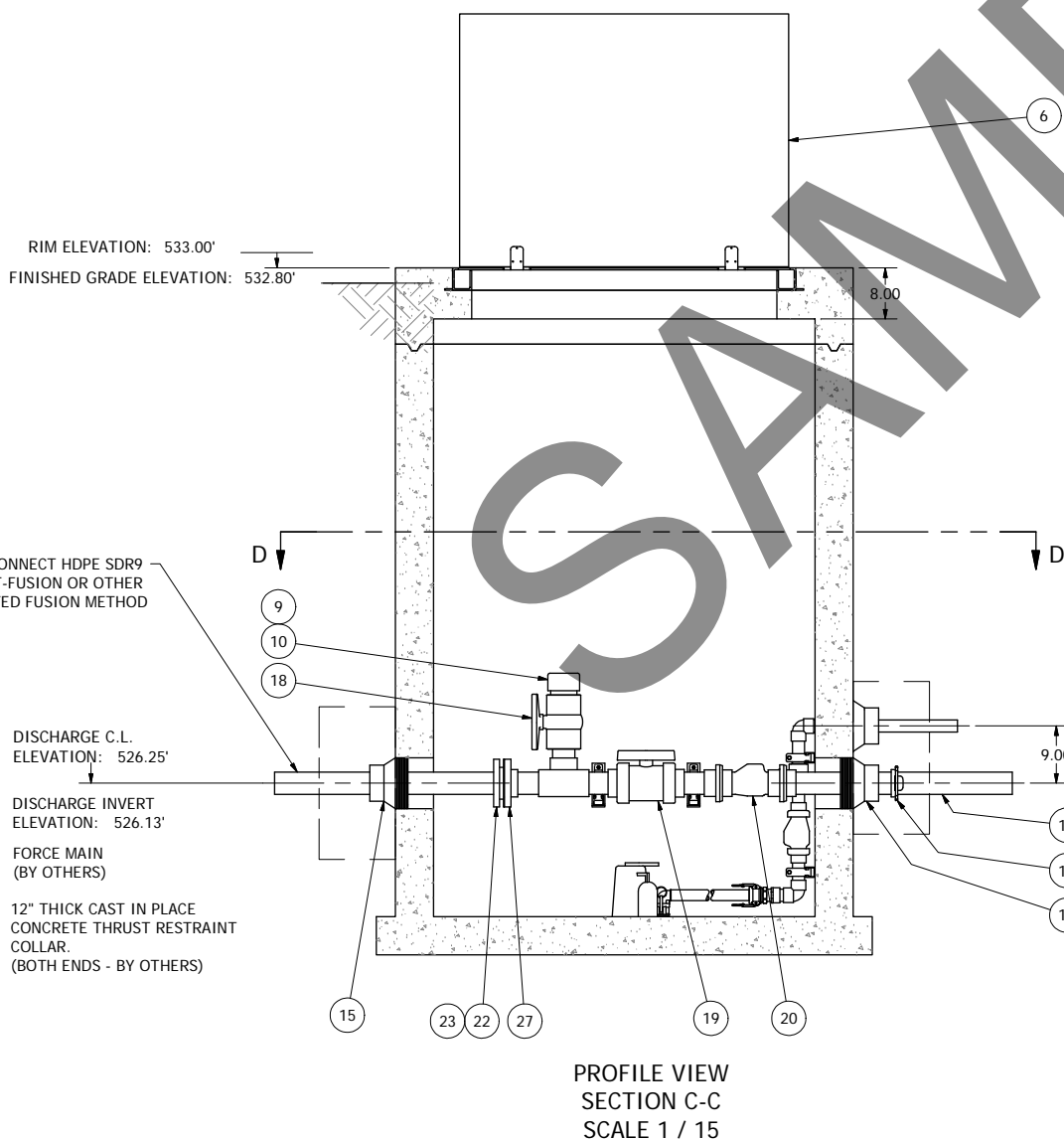

NOTE: ALL DIMENSIONS AND ELEVATIONS SHOWN
ARE NOMINAL DIMENSIONS. IT IS THE RESPONSIBILITY
OF THE ON-SITE CONTRACTOR OR ROMTEC UTILITIES
CUSTOMER (NOT ROMTEC UTILITIES) TO VERIFY THE
ACCURACY OF ANY CRITICAL DIMENSIONS OR ELEVATIONS
PRIOR TO SETTING OR INSTALLING ANY EQUIPMENT.

© 2016 ROMTEC INC. ALL RIGHTS RESERVED. THESE
PLANS AND DRAWINGS MAY NOT BE REPRODUCED,
ADAPTED, OR FURTHER DISTRIBUTED, AND NO
COMPONENTS MAY BE CONSTRUCTED FROM THESE
PLANS, WITHOUT WRITTEN PERMISSION OF ROMTEC, INC.

3	REVISED ELEVATIONS AND ADDED DIMENSIONS	4-5-17	AD
2	VAULT SIZE CHANGED FROM 3.5 FT X 4.5 FT TO 4 FT X 5 FT INSIDE DIMENSION PER CPRP	4-3-17	AD
1	PART NUMBER UPDATE	3-30-17	KB
0	INITIAL DESIGN	5-12-16	KB
REV	DESCRIPTION	DATE	APPROV

VERIFY SCALE
BAR IS ONE INCH ON
ORIGINAL DRAWING

1"
IF NOT ONE INCH ON
THIS SHEET, ADJUST
SCALE PROPORTIONALLY

0

DSN - KEVIN BOGAN
DRN - KEVIN BOGAN
CKD - 5-12-16
DATE - 5-12-16

REVISION HISTORY

**COMPONENT
DRAWING**

**ROMTEC
UTILITIES**
18240 NORTH BANK ROAD
ROSEBURG, OREGON 97470
(541) 496-9678
FAX (541) 496-0804

**GCT ECTC
VALVE VAULT ASSEMBLY**

SHEET
2 OF 2

JOB NUMBER
**RMTC
0000**