

SENSOR AND ELEVATION TABLE		
LEVEL ELEVATION	DISTANCE BETWEEN POINTS	SET POINT DESCRIPTION
345.12		INVERT IN
349.80		BACK UP PUMPS START
	1.00	SENSOR SPACING
348.80		BACK UP PUMPS STOP
	0.00	SENSOR SPACING
348.30		BACK UP HL ALARM
348.80		HIGH LEVEL ALARM
	0.45	SENSOR SPACING
348.35		LAG PUMP START
	1.95	SENSOR SPACING
346.40		LEAD PUMP START
	3.00	SENSOR SPACING
343.40		PUMP STOP
	3.00	DISTANCE TO FLOOR
340.40		FLOOR ELEVATION

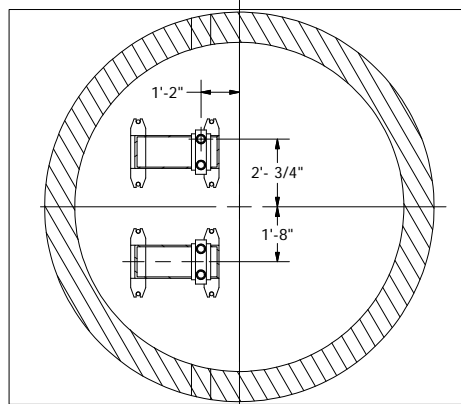

ANCHOR BOLT DETAIL

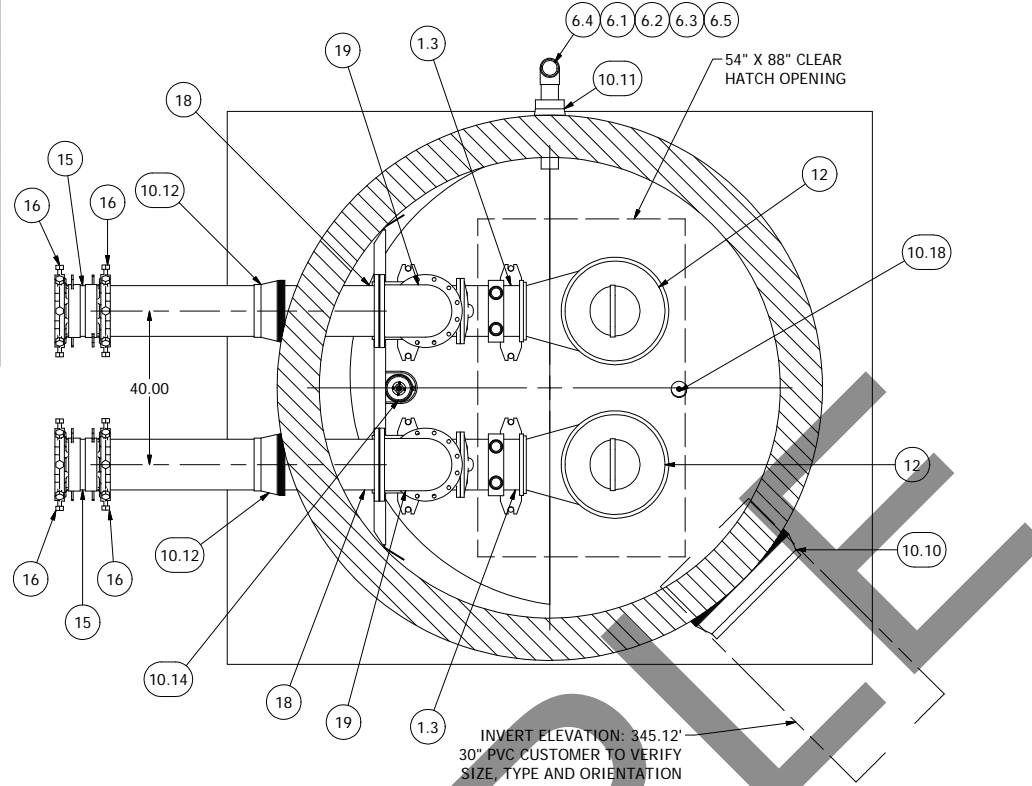

INVERT ELEVATION: 345.12'  
30" PVC CUSTOMER TO VERIFY SIZE, TYPE AND ORIENTATION

**NOTE: WET WELL TOP SLAB IS PEDESTRIAN RATED**

NOTE: ALL DIMENSIONS AND ELEVATIONS SHOWN ARE NOMINAL DIMENSIONS. IT IS THE RESPONSIBILITY OF THE ON-SITE CONTRACTOR OR ROMTEC UTILITIES CUSTOMER (NOT ROMTEC UTILITIES) TO VERIFY THE ACCURACY OF ANY CRITICAL DIMENSIONS OR ELEVATIONS PRIOR TO SETTING OR INSTALLING ANY EQUIPMENT.

**10' DIAMETER WET WELL  
12" DISCHARGE PIPING  
300DLF630 EBARA PUMPS**

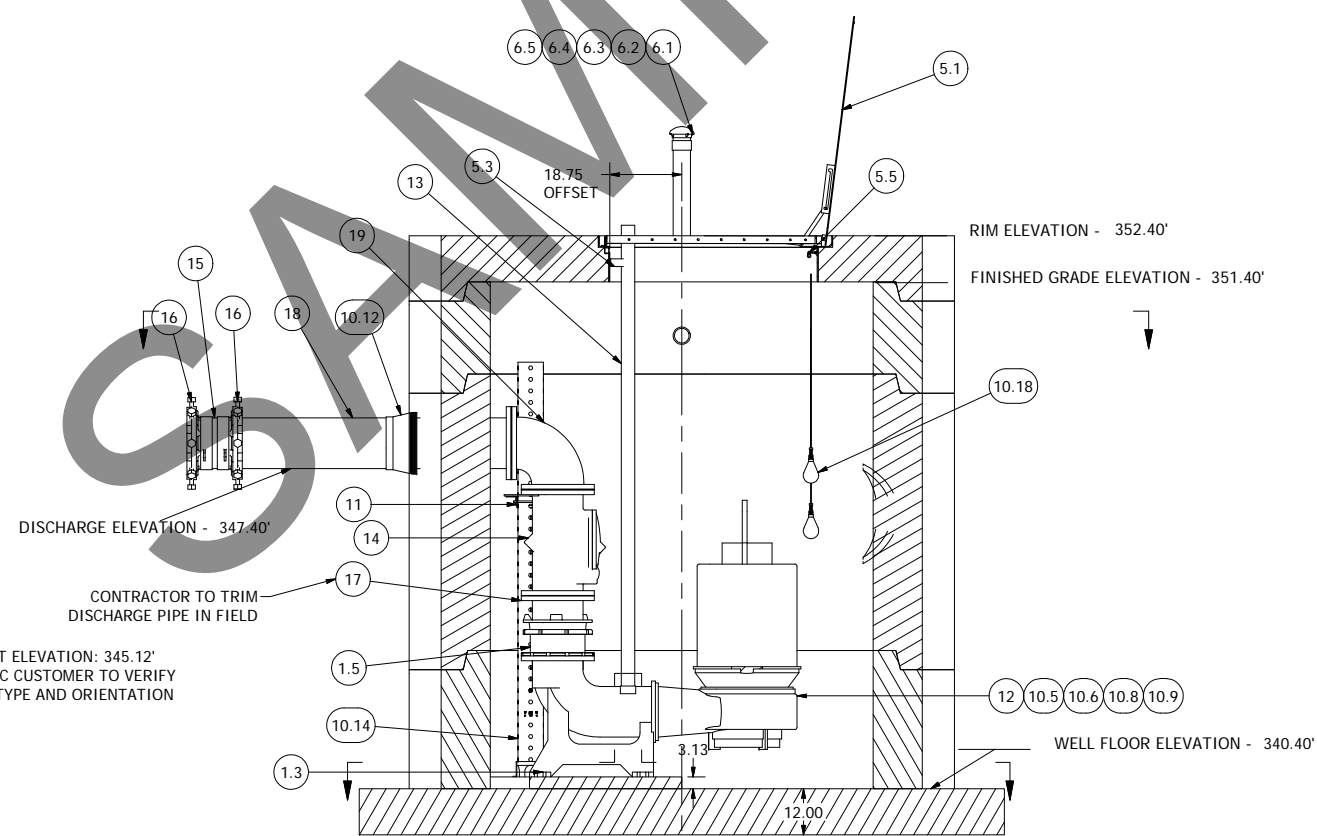
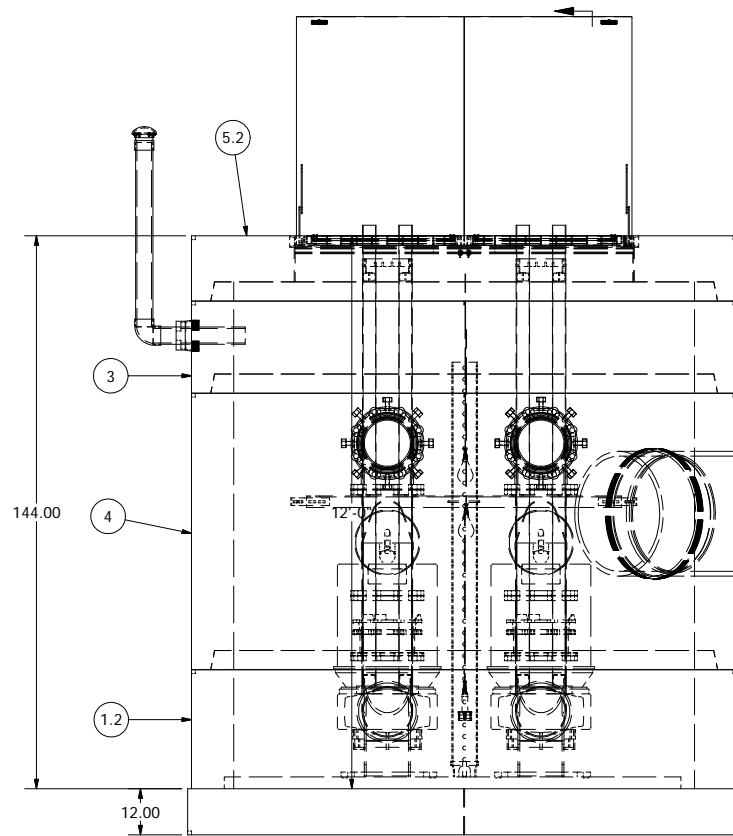

INVERT ELEVATION: 345.12'  
30" PVC CUSTOMER TO VERIFY SIZE, TYPE AND ORIENTATION

ALL MATERIALS SHOWN ON THIS SHEET WILL BE SUPPLIED BY ROMTEC UTILITIES AND DELIVERED TO THE SITE AFTER THE HOLE HAS BEEN EXCAVATED AND SHORED. THE CONTRACTOR SHALL SUPPLY A CRANE OF SUFFICIENT SIZE TO LOWER ALL THE CONCRETE PIECES INTO THE HOLE SAFELY. THE CONTRACTOR SHALL INSTALL THE WET WELL (AND VALVE VAULT AND METERING VAULT IF APPLICABLE). ROMTEC UTILITIES WILL PROVIDE A REPRESENTATIVE FOR TECHNICAL ASSISTANCE ON THE DAY OF INSTALLATION TO ANSWER ANY QUESTIONS THAT MAY ARISE. THE CONTRACTOR IS RESPONSIBLE FOR ALL PLUMBING AND ELECTRICAL CONNECTIONS AND INSTALLATION. ITEMS NOTED AS "BY OTHERS" WILL BE PROVIDED AND INSTALLED BY THE CONTRACTOR. ROMTEC UTILITIES WILL NOT INSTALL ANY OF THE COMPONENTS SHOWN ON THIS PAGE.

REV	DESCRIPTION	DATE	APPROV
2	REVISED BASE TO HAVE 3/4" RISE PER LAUNCH MEETING	3-10-14	AD
1	PER COMMENT LOG	2-26-14	NVA
1	DESCRIPTION	9-16-13	NVA
1	DESCRIPTION	9-16-13	NVA

VERIFY SCALE  
BAR IS ONE INCH ON ORIGINAL DRAWING  
1"  
IF NOT ONE INCH ON THIS SHEET, ADJUST SCALES APPROPRIATELY  
0

DSN - NG  
DRN - NG  
CKD - AD  
DATE - 8/13/13

**ROMTEC UTILITIES**  
18240 NORTH BANK ROAD  
ROSEBURG, OREGON 97470  
(541) 496-9678  
FAX (541) 496-0804

INDIAN SPRINGS SW  
10' WET WELL - 12" DISCHARGE

SHEET  
1 OF 1

JOB NUMBER  
RMTC  
0000