

NOTE:
CONDUIT TO CONTROL PANEL (BY OTHERS)
MINIMUM:
(2) FOR POWER
(1) FOR LEVEL SENSING

FLOAT, PRESSURE TRANSDUCER
AND TEMPERATURE MONITOR CABLES
ARE TO BE ROUTED UP THROUGH
THIS SPOOL AND 2in TAPPED HOLE.

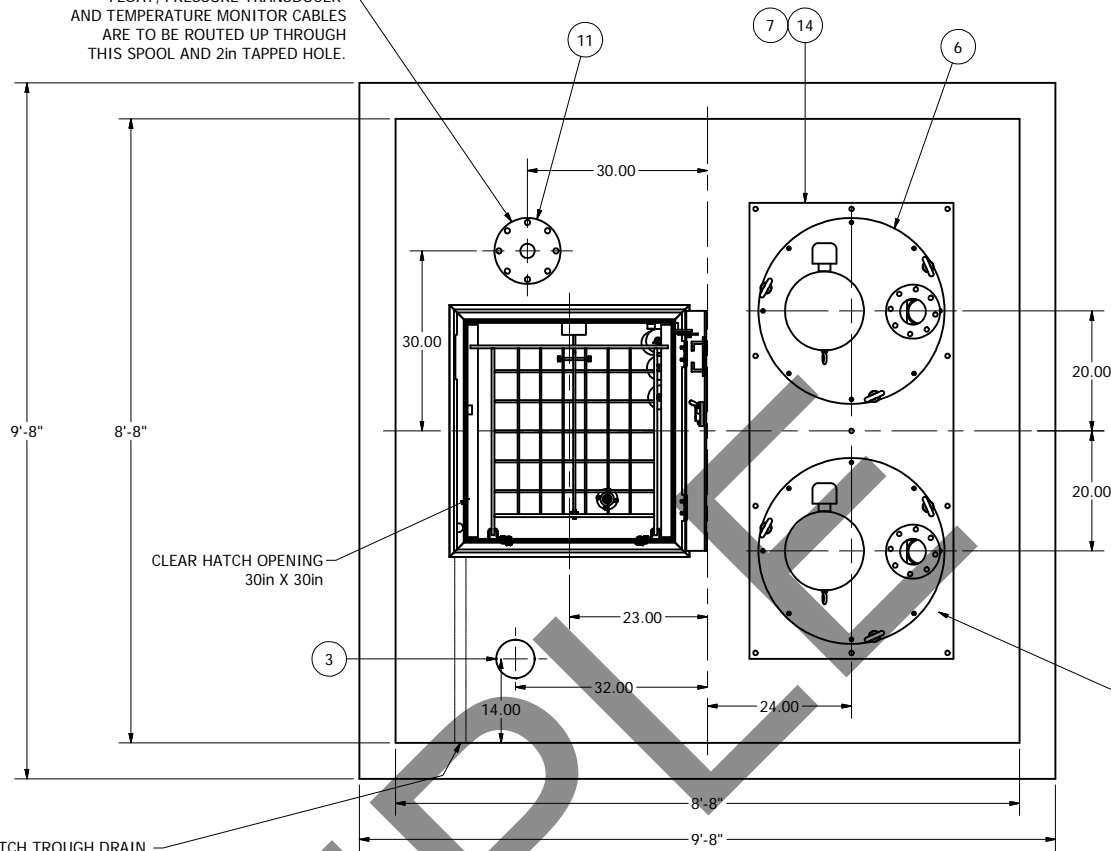

WATER TABLE IS 8ft - 10ft BELOW GRADE

NOTE: WET WELL TOP SLAB IS PEDESTRIAN RATED

FLOAT, PRESSURE TRANSDUCER
AND TEMPERATURE MONITOR CABLES
ARE TO BE ROUTED UP THROUGH
THIS SPOOL AND 2in TAPPED HOLE.

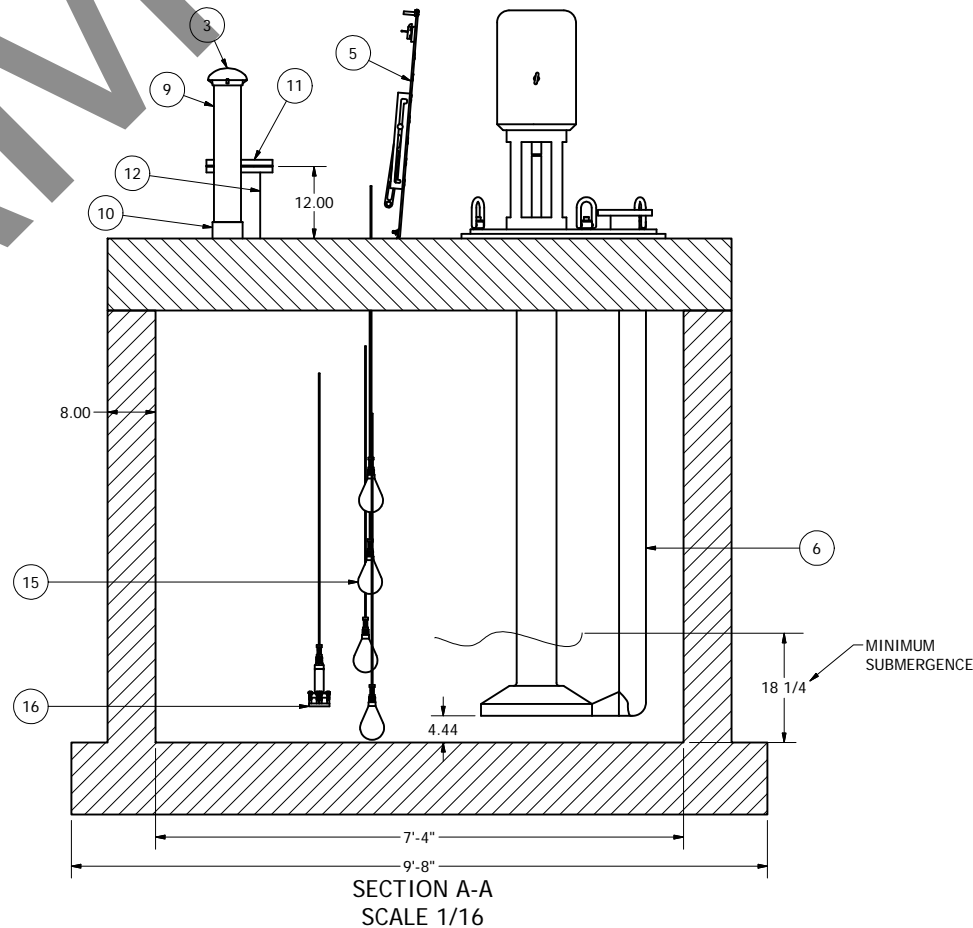
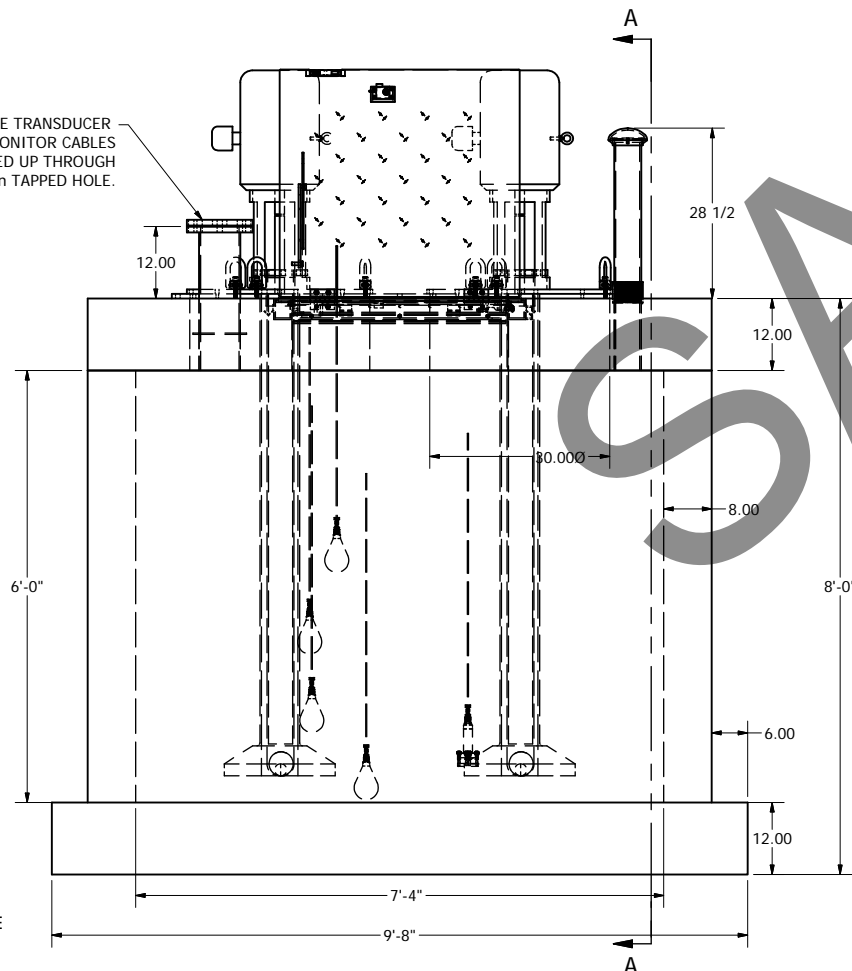

NOTE: ALL DIMENSIONS AND ELEVATIONS SHOWN
ARE NOMINAL DIMENSIONS. IT IS THE RESPONSIBILITY
OF THE ON-SITE CONTRACTOR OR ROMTEC UTILITIES
CUSTOMER (NOT ROMTEC UTILITIES) TO VERIFY THE
ACCURACY OF ANY CRITICAL DIMENSIONS OR ELEVATIONS
PRIOR TO SETTING OR INSTALLING ANY EQUIPMENT.

ALL MATERIALS SHOWN ON THIS SHEET WILL BE
SUPPLIED BY ROMTEC UTILITIES AND DELIVERED TO
THE SITE AFTER THE HOLE HAS BEEN EXCAVATED
AND SHORED. THE CONTRACTOR SHALL SUPPLY A
CRANE OF SUFFICIENT SIZE TO LOWER ALL THE
CONCRETE PIECES INTO THE HOLE SAFELY. THE
CONTRACTOR SHALL INSTALL THE WET WELL
(AND VALVE VAULT AND METERING VAULT IF
APPLICABLE). ROMTEC UTILITIES WILL PROVIDE A
REPRESENTATIVE FOR TECHNICAL ASSISTANCE ON
THE DAY OF INSTALLATION TO ANSWER ANY QUESTIONS
THAT MAY ARISE. THE CONTRACTOR IS RESPONSIBLE
FOR ALL PLUMBING AND ELECTRICAL CONNECTIONS
AND INSTALLATION. ITEMS NOTED AS "BY OTHERS"
WILL BE PROVIDED AND INSTALLED BY THE CONTRACTOR.
ROMTEC UTILITIES WILL NOT INSTALL ANY OF THE
COMPONENTS SHOWN ON THIS PAGE.

© 2016 ROMTEC INC. ALL RIGHTS RESERVED. THESE
PLANS AND DRAWINGS MAY NOT BE REPRODUCED,
ADAPTED, OR FURTHER DISTRIBUTED, AND NO
COMPONENTS MAY BE CONSTRUCTED FROM THESE
PLANS, WITHOUT WRITTEN PERMISSION OF ROMTEC, INC.

REV	DESCRIPTION	DATE	APPROV
2	REVISED HOLE UNDER PUMP TO 30" DIAMETER	8-4-16	AD
1	ADDED DIMENSIONS TO THE TOP SLAB	6-30-16	AD
1	DESCRIPTION	DATE	APPROV

VERIFY SCALE
BARE IS ONE INCH ON
ORIGINAL DRAWING
1"
IF NOT ONE INCH ON
SCALE ACCORDINGLY

DSN - AD
DRN - AD
CKD - AD
DATE - 6-17-16

COMPONENT
DRAWING

ROMTEC UTILITIES
18240 NORTH BANK ROAD
ROSEBURG, OREGON 97470
(541) 496-9678
FAX (541) 496-0804

GEMMA POWER

MIDDLETOWN - HRSG
8ft X 8ft - SUMP PUMP

SHEET
1 OF 1

JOB NUMBER
RMTc

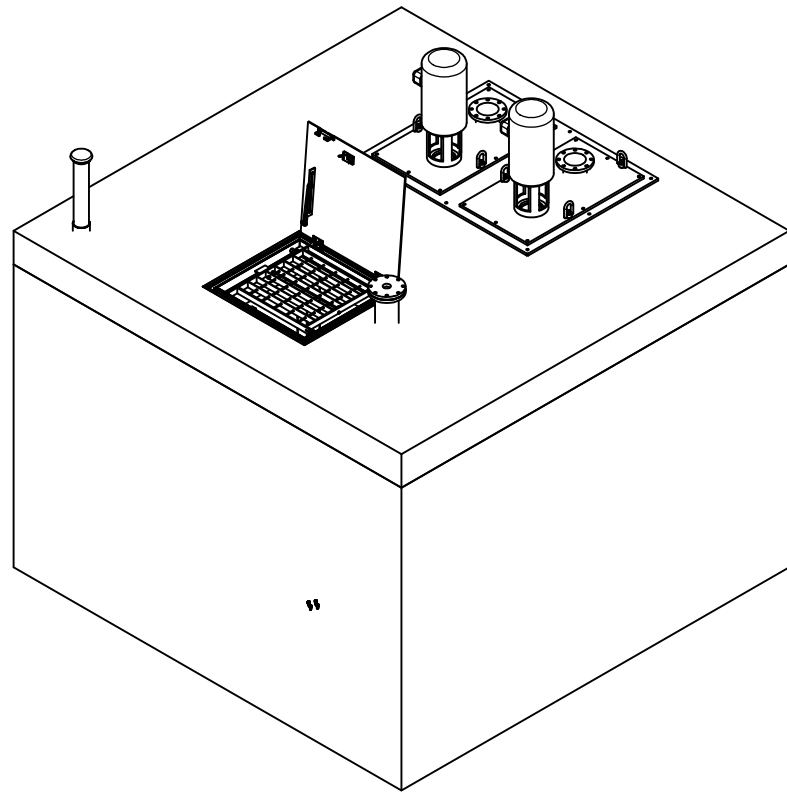

NOTE:
CONDUIT TO CONTROL PANEL (BY OTHERS)
MINIMUM:
(2) FOR POWER
(1) FOR LEVEL SENSING

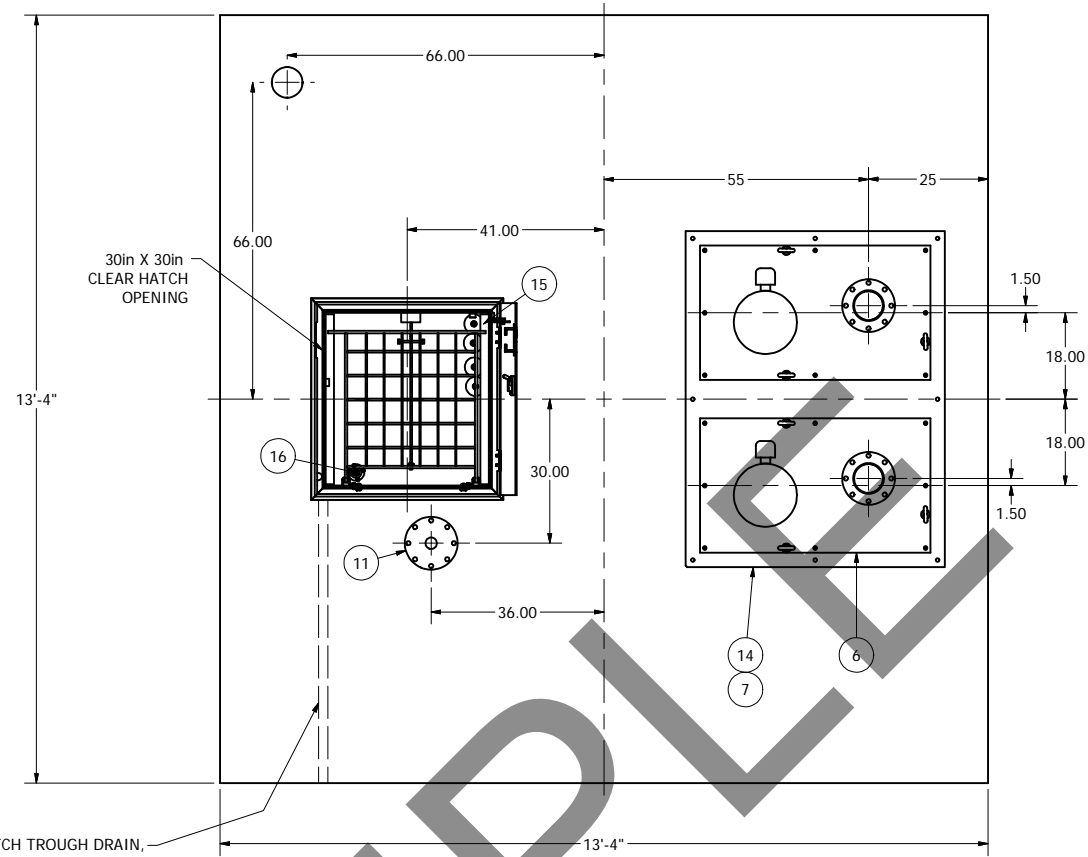

HATCH TROUGH DRAIN,
PLUMBED OUT THE SIDE OF
THE TOP SLAB, 1-1/2in PIPE.

NOTE: WET WELL TOP SLAB IS PEDESTRIAN RATED

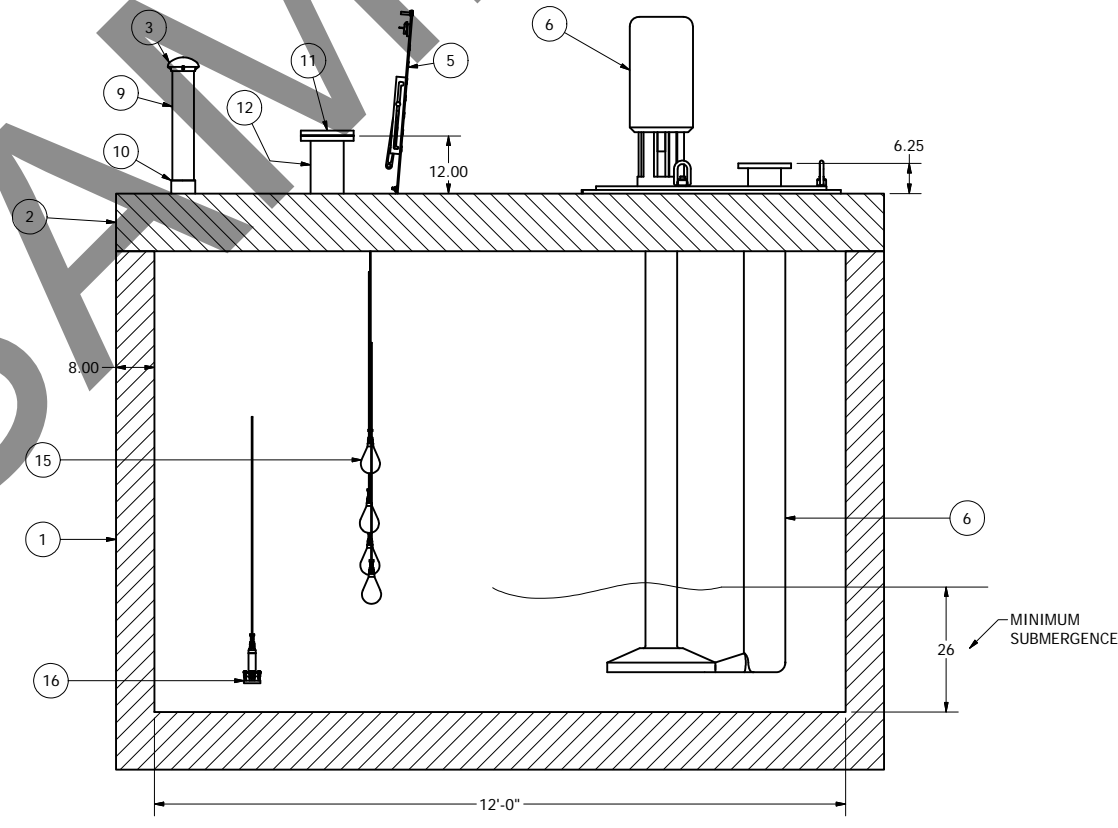
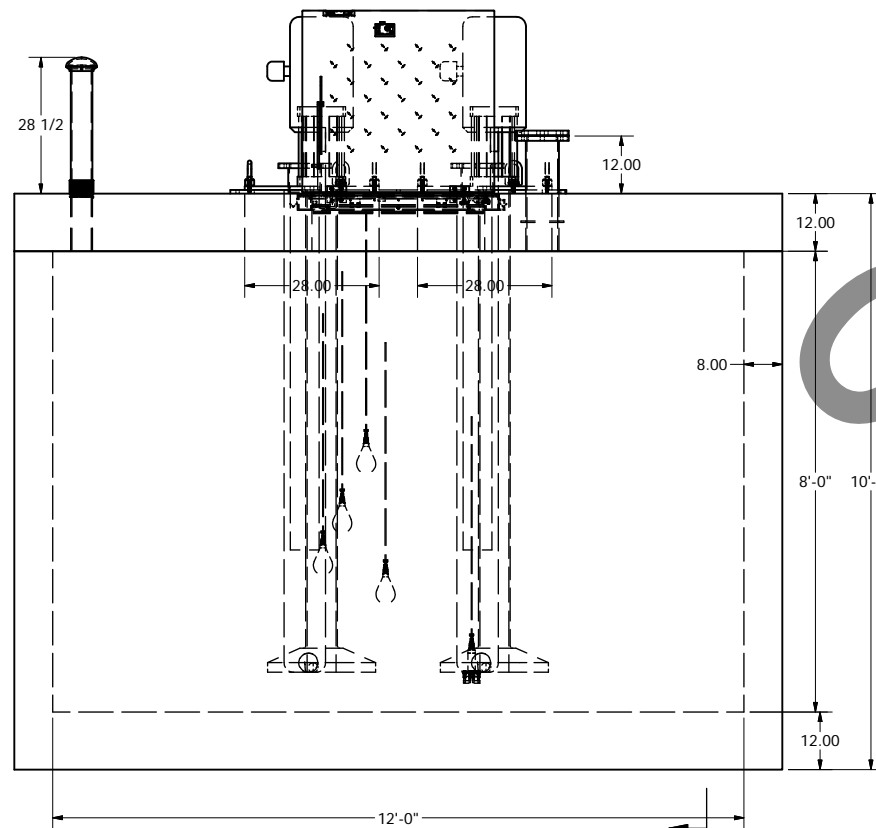

SECTION A-A
SCALE 1/20

ALL MATERIALS SHOWN ON THIS SHEET WILL BE SUPPLIED BY ROMTEC UTILITIES AND DELIVERED TO THE SITE AFTER THE HOLE HAS BEEN EXCAVATED AND SHORED. THE CONTRACTOR SHALL SUPPLY A CRANE OF SUFFICIENT SIZE TO LOWER ALL THE CONCRETE PIECES INTO THE HOLE SAFELY. THE CONTRACTOR SHALL INSTALL THE WET WELL (AND VALVE VAULT AND METERING VAULT IF APPLICABLE). ROMTEC UTILITIES WILL PROVIDE A REPRESENTATIVE FOR TECHNICAL ASSISTANCE ON THE DAY OF INSTALLATION TO ANSWER ANY QUESTIONS THAT MAY ARISE. THE CONTRACTOR IS RESPONSIBLE FOR ALL PLUMBING AND ELECTRICAL CONNECTIONS AND INSTALLATION. ITEMS NOTED AS "BY OTHERS" WILL BE PROVIDED AND INSTALLED BY THE CONTRACTOR. ROMTEC UTILITIES WILL NOT INSTALL ANY OF THE COMPONENTS SHOWN ON THIS PAGE.

NOTE: ALL DIMENSIONS AND ELEVATIONS SHOWN ARE NOMINAL DIMENSIONS. IT IS THE RESPONSIBILITY OF THE ON-SITE CONTRACTOR OR ROMTEC UTILITIES CUSTOMER (NOT ROMTEC UTILITIES) TO VERIFY THE ACCURACY OF ANY CRITICAL DIMENSIONS OR ELEVATIONS PRIOR TO SETTING OR INSTALLING ANY EQUIPMENT.

© 2016 ROMTEC INC. ALL RIGHTS RESERVED. THESE PLANS AND DRAWINGS MAY NOT BE REPRODUCED, ADAPTED, OR FURTHER DISTRIBUTED, AND NO COMPONENTS MAY BE CONSTRUCTED FROM THESE PLANS, WITHOUT WRITTEN PERMISSION OF ROMTEC, INC.

VERIFY SCALE BARE IS ONE INCH ON ORIGINAL DRAWING 0 1"	DESCRIPTION	DATE	APPROV
IF NOT ONE INCH ON SCALES ACCORDINGLY	REVISION HISTORY		
DSN - AD	1		
DRN - AD	REV		
CKD - AD			
DATE - 6-17-16			

COMPONENT
DRAWING

ROMTEC UTILITIES
18240 NORTH BANK ROAD
ROSEBURG, OREGON 97470
(541) 496-9678
FAX (541) 496-0804

GEMMA POWER
MIDDLETOWN - PROCESS WATER
12ft X 12ft - SUMP PUMP

SHEET
1 OF 1

JOB NUMBER
RMTCT