

VERIFY SCALE  
BAR IS ONE INCH ON  
ORIGINAL DRAWING

1"

IF NOT ONE INCH ON  
THIS SHEET, ADJUST  
SCALE APPROPRIATELY

0

DSN - AD  
DIRN - AD  
CKD - AD  
DATE - 6-28-13

COMPONENT  
DRAWING

**ROMTEC  
UTILITIES**  
18240 NORTH BANK ROAD  
ROSEBURG, OREGON 97470  
(541) 496-9678  
FAX (541) 496-0804

STEVENS PASS  
WET WELL RETROFIT

SHEET  
1 OF 1

JOB NUMBER  
RMTC  
0000

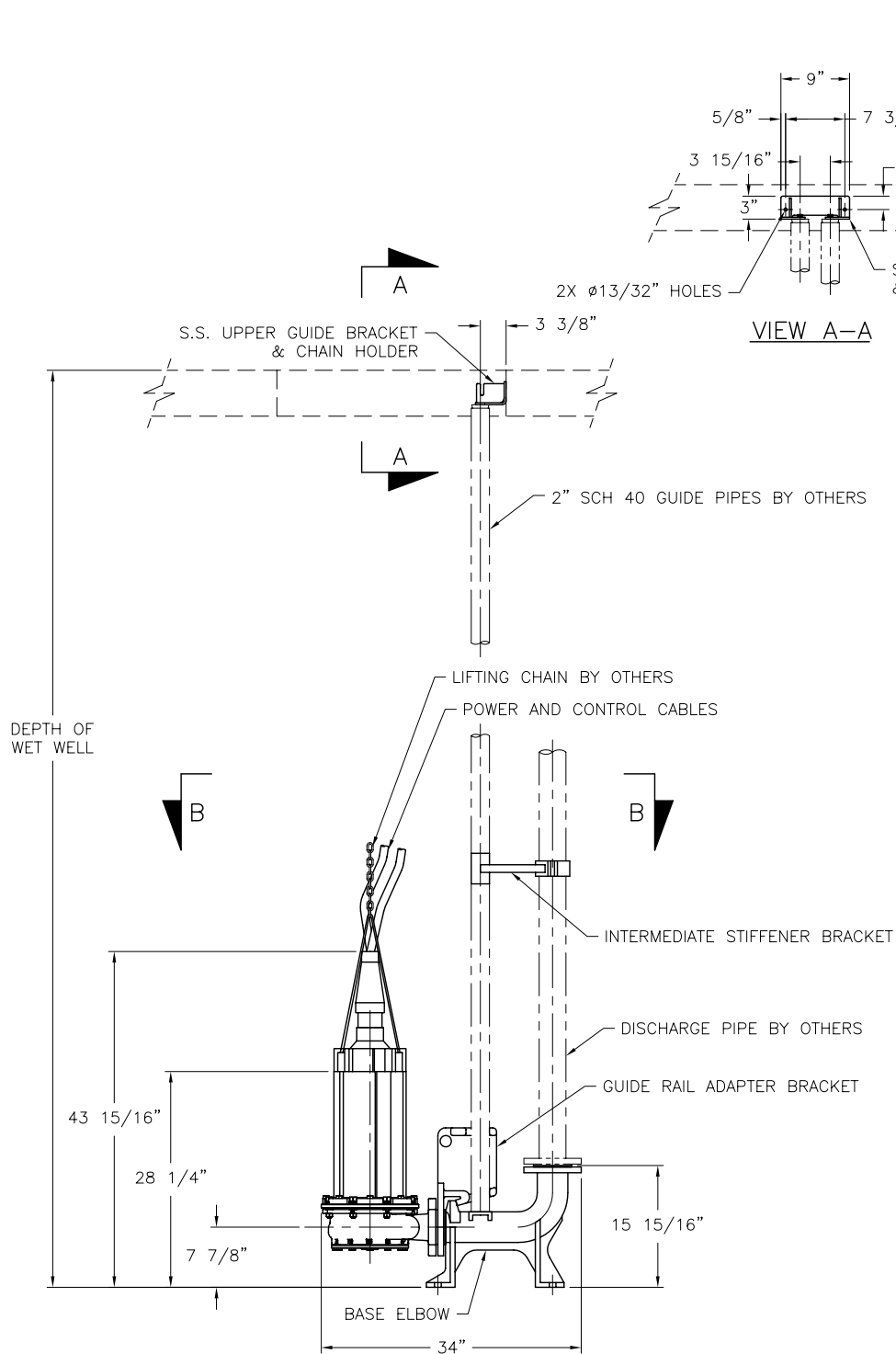

**NOTES:**

1. PUMP WEIGHT: LBS
2. MOTOR WEIGHT: 200 LBS
3. TOTAL WEIGHT: LBS
4. PERFORMANCE REQUIRED: GPM @ TDH
5. MOTOR: HP, RPM  
POWER: V, PH, HZ  
ENCLOSURE: SUBMERSIBLE, 180TY FRAME  
MANUFACTURED BY: RELIANCE
6. SURFACE PREPARATION:

	VAUGHAN CO., INC. 364 MOATE-ELMA ROAD MONTESANO, WA 98863 PHONE: (360) 249-4042 FAX: (360) 249-6155		TITLE: <b>OUTLINE DIMENSIONS</b> MODEL: SE3L1-	
	THIS DRAWING IS THE PROPERTY OF VAUGHAN COMPANY, INC. IT IS FURNISHED FOR YOUR CONFIDENTIAL INFORMATION PURPOSES ONLY, AND IS NOT TO BE DISCLOSED TO ANYONE ELSE OR REPRODUCED OR USED FOR MANUFACTURING PURPOSES WITHOUT THE EXPRESS WRITTEN CONSENT OF VAUGHAN COMPANY, INC.			
VAUGHAN SALES ENGR:		LOCATION:		
THIS DRAWING IS A PROPOSAL DRAWING AS SUCH IT IS A PRELIMINARY DRAWING AND IT SHOULD NOT BE USED FOR CONSTRUCTION PURPOSES.		JOB ORDER NUMBER:	DATE:	VAUGHAN QUOTATION NUMBER: