

PRIMARY SENSOR ELEVATION TABLE		
DESCRIPTION	ELEVATION	Δ
INFLUENT INVERT	86.90	5.50
HIGH LEVEL ALARM	81.40	0.25
LAG PUMP START	81.15	0.50
LEAD PUMP START	80.65	0.25
PUMP STOP	80.40	1.50
WELL FLOOR	78.90	

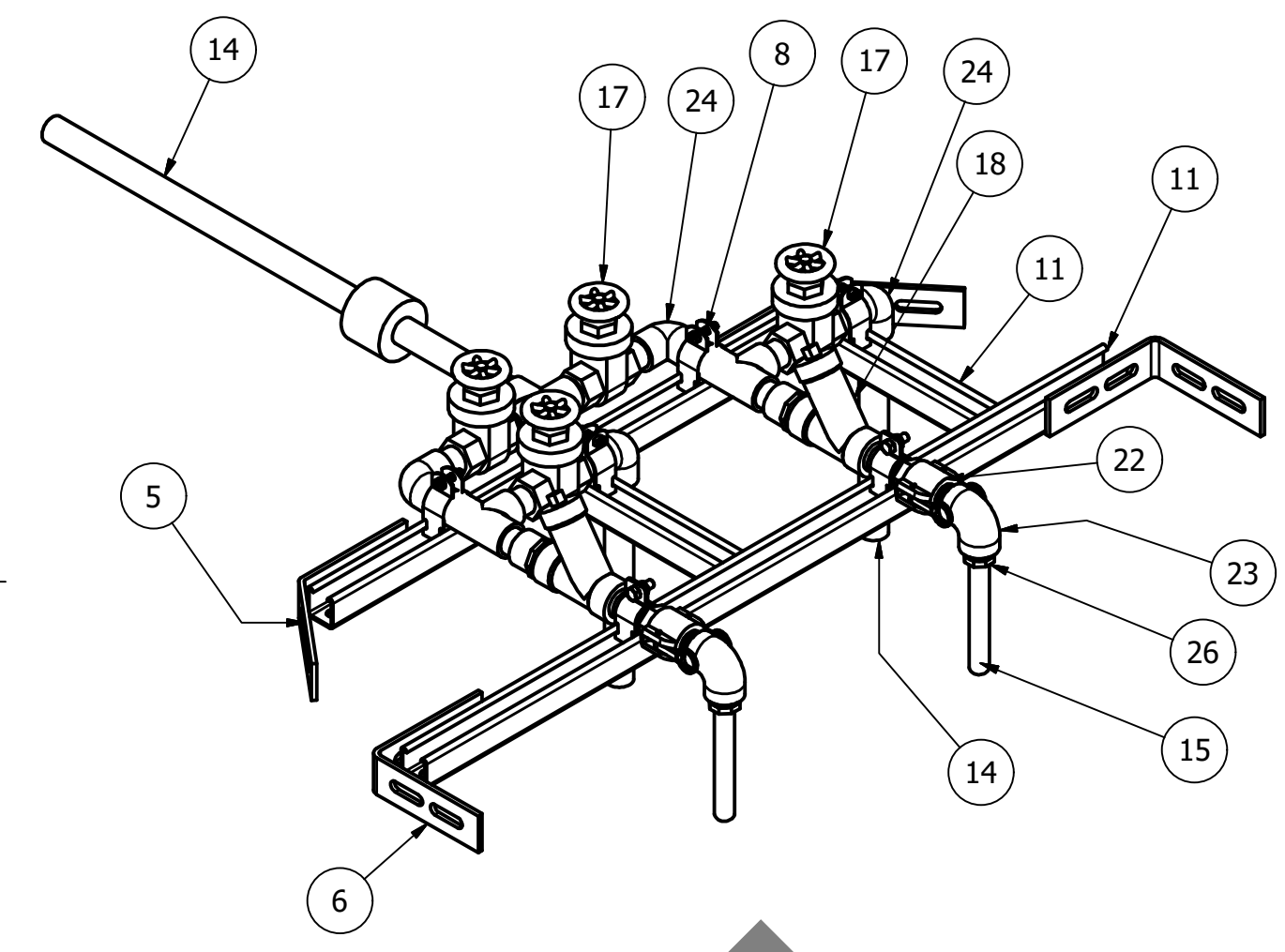
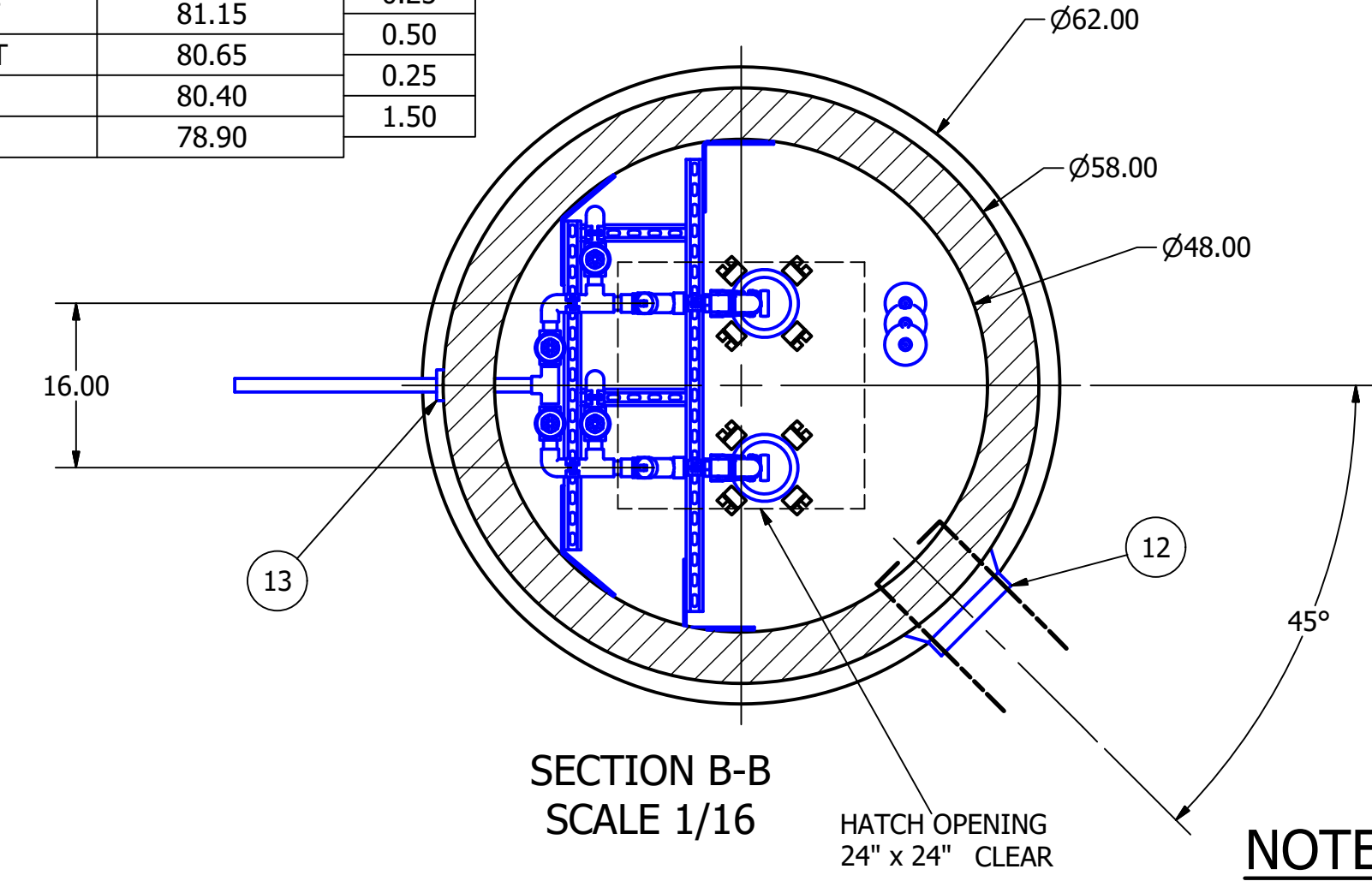

NOTE: TOP SLAB AND HATCH ARE H-20 TRAFFIC RATED

NOTE: CONDUIT TO CONTROL PANEL (BY OTHERS) MINIMUM:
 (2) FOR POWER
 (1) FOR LEVEL SENSING

COLOR LEGEND

- MAJOR CONCRETE COMPONENTS WITH PRE-INSTALLED COMPONENTS.
- COMPONENTS PRE-ASSEMBLED TO THE EXTENT POSSIBLE AND WILL NEED TO BE FIELD INSTALLED.

NOTE: PRE-ASSEMBLY IS DONE AT ROMTEC UTILITIES' DISCRETION AND MAY CHANGE AT THE TIME OF PRODUCTION.

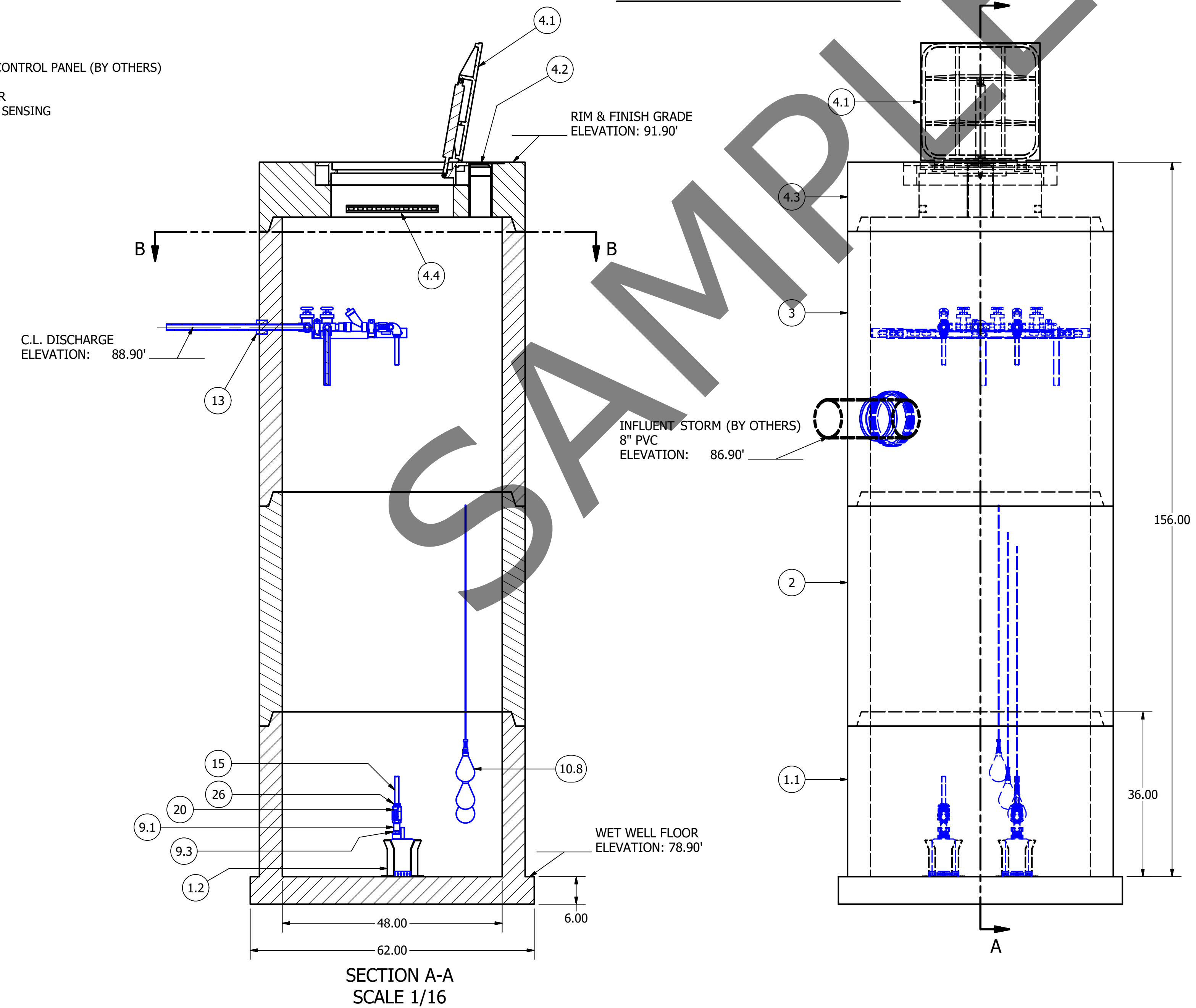

**4' DIAMETER WET WELL
 1" DISCHARGE PIPING
 EBARA SUMP PUMPS**

FOR DESIGN REVIEW

NOTE: CONTRACTOR TO SEAL ALL CONCRETE JOINTS AND PIPE PENETRATIONS WITH NON-SHRINK GROUT

NOTE: ALL DIMENSIONS AND ELEVATIONS SHOWN ARE NOMINAL DIMENSIONS. IT IS THE RESPONSIBILITY OF THE ON-SITE CONTRACTOR OR ROMTEC UTILITIES CUSTOMER (NOT ROMTEC UTILITIES) TO VERIFY THE ACCURACY OF ANY CRITICAL DIMENSIONS OR ELEVATIONS PRIOR TO SETTING OR INSTALLING ANY EQUIPMENT.

ALL MATERIALS SHOWN ON THIS SHEET WILL BE SUPPLIED BY ROMTEC UTILITIES AND DELIVERED TO THE SITE AFTER THE HOLE HAS BEEN EXCAVATED AND SHORED. THE CONTRACTOR SHALL SUPPLY A CRANE OF SUFFICIENT SIZE TO LOWER ALL THE CONCRETE PIECES INTO THE HOLE SAFELY. THE CONTRACTOR SHALL INSTALL THE WET WELL (AND VALVE VAULT AND METERING VAULT IF APPLICABLE). ROMTEC UTILITIES WILL PROVIDE A REPRESENTATIVE FOR TECHNICAL ASSISTANCE ON THE DAY OF INSTALLATION TO ANSWER ANY QUESTIONS THAT MAY ARISE. THE CONTRACTOR IS RESPONSIBLE FOR ALL PLUMBING AND ELECTRICAL CONNECTIONS AND INSTALLATION. ITEMS NOTED AS "BY OTHERS" WILL BE PROVIDED AND INSTALLED BY THE CONTRACTOR. ROMTEC UTILITIES WILL NOT INSTALL ANY OF THE COMPONENTS SHOWN ON THIS PAGE.

ROMTEC UTILITIES
 18240 NORTH BANK RD.
 ROSEBURG, OR 97470 (541) 496-9678
 © 2019 ROMTEC INC. ALL RIGHTS RESERVED. THESE PLANS AND DRAWINGS MAY NOT BE REPRODUCED, ADAPTED, OR FURTHER DISTRIBUTED, AND NO COMPONENTS MAY BE CONSTRUCTED FROM THESE PLANS, WITHOUT WRITTEN PERMISSION OF ROMTEC, INC.

STARBUCKS 620
 SAN CLEMENTE, CA

WET WELL ASSEMBLY
 COMPONENT DRAWING

MECHANICAL SHEET
 3 OF 4

VERIFY SCALE
 0 1"

DSN: AD
 DRN: AD
 CKD: AD

DATE: 12-6-18

ROMTEC UTILITIES
 18240 NORTH BANK ROAD
 ROSEBURG, OREGON 97470
 PHONE: (541) 496-9678
 WWW.ROMTECUTILITIES.COM

REVISION HISTORY